

**CARATTERISTICHE DESCRITTIVE**

SPESSORE ISOLAMENTO 70 mm

ACCIAIO INOX AISI 304

SPIGOLI ARROTONDATI

EVAPORATORE CON TRATTAMENTO CATAFORESI

PASSO 65 mm

**ACCESSORI**

**ACC 509**  
Sonda cuore riscaldata

**ACC 140**  
Kit 4 Ruote

**ACC 110**  
Sterilizzatore a ozono

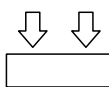
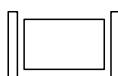
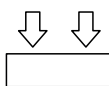
**ACC 135**  
Apertura Porta Sx

**ACC 154**  
Adattatore Appoggio  
Forno Rational

**ACC 800/1**  
Maggiorazione  
Portateglie EN 60X40

**ACC 155**  
Adattatore Appoggio  
Forno

 Supplemento  
voltaggio speciale

**CONDIZIONI AMBIENTALI**

+32°C

60% UR

**SPECIFICHE SECONDO prEN 17032**

Abbattimento (+65°C / +10°C)		Surgelazione (+65°C / -18°C)	
Capacità max.	Tempo	Capacità max.	Tempo
20 kg	120 min	12 kg	260 min















**CONSUMI (prEN 17032)**

Abbattimento	Surgelazione
+90°C / +3°C	+90°C / -18°C
0,12 kWh/kg	0,40 kWh/kg

**GAS REFRIGERANTE**

Tipo	GWP	Carica
R452A	2141	1,0 kg

DATI GENERALI

 Modello	<b>MXE5.20</b>	 Tensione standard	230 V / 1 Ph 50 Hz	 Resa Frigorifera -30°C	700 W Evap. -30°C Cond. +45°C
 Versione	ARIA	 Potenza assorbita	1,3 kW / 7,0 A	 Dimensioni	798 x 700 x 835/865 mm
 Capacità	5 GN1/1 5 EN 60X40	 HP	1,1 HP	 Peso	100 kg
 Abbattimento	20 kg +90°C → +3°C 90 min	 Rumorosità	<70 dB	 Allestimento	<b>GN 1/1 EN 60X40</b>
 Surgelazione	12 kg +90°C → -18°C 240 min	 Resa Frigorifera -10°C	1.750 W Evap. -10°C Cond. +45°C		

ALLESTIMENTO

**ACTIVA** GN 1/1 - EN 60X40

●	Abbattimento positivo (+3°C)
●	Surgelazione (-18°C)
●	Mantenimento positivo (+3°C)
●	Mantenimento negativo (-18°C)

DIMENSIONI

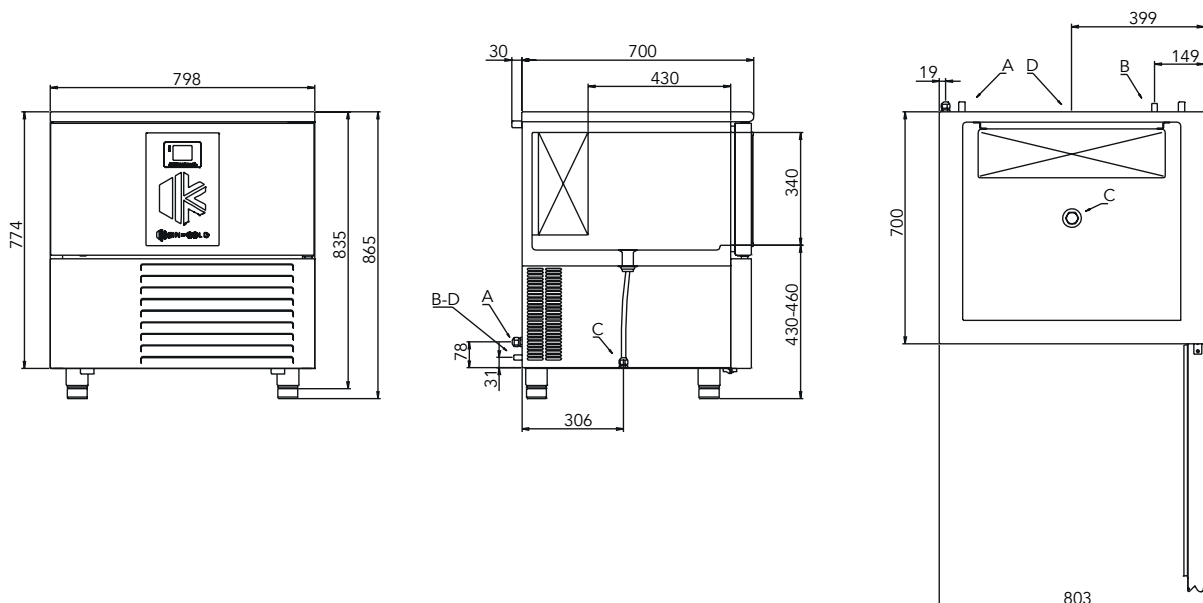

COLLEGAMENTI

- A** Connessione elettrica
- B** Collegamento idrico (su richiesta)
- C** Scarico condense
- D** Collegamento frigorifero (su richiesta)